

**CITY OF FARGO SPECIFICATIONS
STREET LIGHTING**

**PART 1
DESCRIPTION OF WORK**

The work to be done under this section of the Specifications shall consist of furnishing and installing a complete and operational street lighting system.

PART 2
MATERIALS

2.1. GENERAL

The Contractor shall furnish the specified material unless substitute materials are approved in writing by the Engineer.

2.2. RIGID CONDUIT

2.2.1. NONMETALIC CONDUIT

Nonmetallic conduit shall be 1.5” high-density polyethylene (HDPE) innerduct unless otherwise shown on Plans. Polyvinyl chloride (heavy wall – PVC) will be allowed in certain situations with written approval from the project Engineer.

2.2.1.1. HDPE. HDPE innerduct shall meet the requirements of UL 651 and either ASTM 2447 or ASTM 3035 suitable for direct burial applications. HDPE innerduct shall have a minimum wall thickness equivalent to Schedule 40 as defined by ASTM 2447 or DR 15.5 as defined by ASTM 3035. HDPE innerduct shall not be installed when either the innerduct temperature or ambient temperature is below –10 F.

2.2.1.2. PVC. PVC conduit shall meet the requirements of UL 651 suitable for direct burial applications and shall have a minimum wall thickness equivalent to Schedule 40 as defined by ASTM 1785.

2.3. CONDUCTORS

2.3.1. UNDERGROUND CONDUCTORS

Underground circuit conductors shall be stranded copper, Type “USE”, conductors insulated for direct burial and rated 600 volts. Conductor sheath shall be marked as to voltage, AWG, type (USE), and manufacturer. All conductor shall be continuous color coded (red, black and green). Conductors shall be of the size shown on the Plans.

2.3.2. STREET LIGHT STANDARD CONDUCTOR

The conductor required for the street light standards between distribution conductors and luminaire shall consist of No. 10 AWG stranded copper, Type "USE" and rated 600 volts. Street Light fuses shall be a type FNM 10 amp fuse with a Bussmann type HEB-AA or a Littlefuse type LEB-AA in line fuse holder. Provide ground conductor from the luminaire to the handhole where required by the national electrical code.

2.4. SPLICE CONNECTIONS

Splice connections in street light bases shall be Tyco Electronics GelCap SL splice cover kit with connector. All other conductor splice connections in pull boxes and feed points shall be UL listed, with PowerGel sealant type connections meeting all codes for desired applications.

2.5. PULL BOX**2.5.1. PVC PULL BOX**

Unless otherwise noted on plan, all street light pull boxes shall be PVC with metal frames and covers, and shall conform to the detail included in the plans. Pull boxes in landscaped areas shall have the top of the box 0" to 1" above final grade and sloped to match the slope of the final grade on all 4 quadrants. Pull boxes in concrete area shall be set with the top of the box flush with the final grade at all 4 quadrants.

2.5.2. POLYMER CONCRETE PULL BOX

The minimum size shall be 11" x 18" x 24" deep, with no base. The cover will be 1-3/4" thick, secured with stainless steel bolts, and have a logo of "Street Lights". The base and cover shall be made from a polymer concrete material able to sustain a minimum test load of 12,000#. Color shall be green or gray depending upon location of installation. Carson and Quazite brands are approved for installation.

2.6. FEED POINT

Pedestal type feed point shall be concrete pad mounted (see Plans for size of cabinet and number of circuits). The pedestal cabinet shall have a NEMA 3R rating. The cabinet shall be constructed of 16 gauge #304 stainless steel, stainless steel hardware and a padlockable stainless steel handle with 3-point latch operation, continuous hinged deadfront, 2" drip shield, gasketed lexan photocell window on side and back

of pedestal cabinet. All circuit breakers shall be rated 22,000 AIC. The pedestal cabinet shall also include a factory installed, interior mounted meter trim which meets the size requirements of the local utility company and a viewport window with gasketed lexan located on the front door of pedestal cabinet. Meter shall be provided by the local utility company.

Prefabricated feed point enclosure to be assembled by States Electric, UL 508 listed, service entrance rated, or approved equal.

2.7. STREET LIGHTING STANDARDS

Refer to Plans for information on size and type of standards.

2.8. STREET LIGHTING LUMINAIRES

Refer to Plans for information on size and type of luminaires.

2.8.1. Lamps

All High Pressure Sodium lamps shall be eco style, no cycle lamps. Contractor shall supply and install all lamps.

**PART 3
CONSTRUCTION**

3.1. GENERAL

3.1.1. GENERAL

All work and material shall meet the National Electric Code, the North Dakota State Electrical Board, the local utility company, and the ordinances established by the City of Fargo. All materials shall be new.

3.1.2. SHOP DRAWINGS

The Contractor shall provide an electronic PDF file of shop drawings and certifications required by the City of Fargo within 15 days of the Notice to Proceed sent out after the City Commission has approved the Project. All shop drawings and certifications shall be approved prior to any work being started. A list of required shop drawings will be provided to the Contractor by the Engineer upon request.

The Contractor shall be responsible for the accuracy of the shop drawings. The Engineer's review does not relieve the Contractor of full responsibility for providing a quality product that meets Specifications. The Contractor shall submit shop drawings on the following listed items for approval:

1. Conductors
2. Pull Box
3. Feed Point: cabinet, relays, switches, panels and photo cells.
4. Street Light Standards, including all necessary calculations and drawings used in designing these poles.
5. Street Light Luminaires
6. Items requested by Engineer

3.1.3. WARRANTIES AND GUARANTEES

All manufacturer warranties and guarantees with respect to materials, parts, workmanship, or performance which the products covered by the proposal bear shall be secured and included with the shop drawing submittal.

3.1.4. COORDINATION

The Contractor shall coordinate all work with the City's project Engineer and/or inspector when work activities are scheduled. The electrical Contractor is responsible to coordinate his activities with the underground, paving and landscape Contractors to insure the timely completion of the new street lighting system.

3.1.5. LOCATION OF EXISTING UTILITIES

Partial existing utilities have been shown to direct the Contractor's attention to their existence. Such utilities have been plotted from record drawings.

THE CONTRACTOR IS CAUTIONED THAT ALL EXISTING UTILITIES MAY NOT BE SHOWN. THE LOCATION OF EXISTING UTILITIES IS NOT GUARANTEED, AND THE CONTRACTOR WILL BE RESPONSIBLE FOR DETERMINING THE EXACT LOCATION AND PROTECTION OF THE EXISTING UTILITIES. THE CONTRACTOR, BEFORE COMMENCING ANY EXCAVATION OR CONSTRUCTION, SHALL FIND OUT THE LOCATION AND SEEK AID IN LOCATING ALL PUBLIC AND PRIVATE UTILITIES. THE CONTRACTOR SHALL CONTACT ND ONE-CALL 1-800-795-0555 AND REQUEST LOCATES PRIOR TO BEGINNING CONSTRUCTION.

3.1.6. OVERHEAD LINES CLEARANCE. Minimum horizontal and vertical clearance between street light standards/luminaires and power lines shall be as shown for the following power line voltages:

Power Line Voltage	Horizontal Clearance	Vertical Clearance
0-15,000	5'	6'
15,000-50,000	5'	7'
50,000 Plus	5'+0.033' per KV	7'+0.033' per KV
	Over 50 KV	Over 50 KV

3.2. **CONSTRUCTION REQUIREMENTS**

If the Contractor has a delay in delivery of ordered materials that will affect the completion date of the project and The City of Fargo is able to provide materials for the Contractor to borrow, the Contractor shall borrow the materials from the City by supplying the project from the City's maintenance stock, then replenishing the maintenance stock once the delivery arrives.

3.2.1. **CONCRETE BASE**

See plans for detail of Concrete Base size requirements and construction requirements. It shall be the Contractors responsibility to verify shop drawing information, provided by the manufacturer of the street light standards, for anchor bolt size, bolt circle diameter and anchor bolt projections.

Column forms shall be used for the top 12" of base tops. Square top forms will not be allowed. Verify anchor bolt projection requirements. Conduit with bell end shall have a maximum height of 2" above concrete base surface and the ground rod shall be a maximum of 1-1/2" above conduit with bell end. Finish of the base top shall be level without any irregularities or depressions in the concrete. Grinding of base top or filling of depressions will not be allowed and any base not meeting these requirements will be removed and replaced at the Contractors expense. Column forms shall be removed as part of clean up before landscaping. Bases shall have a minimum seven day cure time before any standards shall be installed. Excess dirt from the drilling of base hole shall be removed from the project site daily.

Concrete shall be a 6 bag mix with a minimum 28-day compressive strength of 3500 p.s.i. Entrained air content shall be between 5% and 8%.

It is the Contractors responsibility to protect any concrete base left over winter. Any base damaged will be replaced at the Contractors expense.

3.2.2. **CONDUIT**

Innerduct shall be 1.5" schedule 40 innerduct, smooth outside, controlled outside diameter at 1.9000. Inside diameter of 1.579, minimum wall thickness of 0.145, and color RED, unless otherwise shown on plans.

Innerduct/conduit shall be installed at the location shown on the plans and will be connected to stubbed out 1.5" conduit at all concrete base and feed point locations. Installation of innerduct

shall be at a minimum depth of 24" below finished grade. The innerduct shall be placed in line with bases behind curb. Innerduct/conduit shall be bored under existing pavement (jacking will only be allowed under existing sidewalks and multi use paths) and in areas of mature trees, established sod and all others locations shown on plans.

All innerduct/conduit shall have Bell Ends installed on both ends of the innerduct/conduit run. All innerduct/conduit containing conductor/cables shall be sealed with duct seal at the feed point cabinets, pull boxes and at the street light standard bases. All spare conduits shall be plugged with an expanding rubber pipe plug at the feed point cabinet, pull boxes and street light standard bases.

3.2.3. CONDUCTORS

Conductors shall be continuous color coded (black, red and green). No splicing of conductors will be allowed without specific approval of ENGINEER. Conductors shall be of the size shown on the Plans.

All street lighting circuits shall be 240V single phase consisting of three conductors, black and red for the phase conductors and a green for the ground conductor.

Distribution circuits shall be routed as shown on plans. Any deviation in routing of circuits must be approved by the project Engineer.

Luminaire or festoon circuits are to be fused in the base of each lighting standard. Tape fuse holders with a 1/2-inch lapped layer for a distance of 1½ inches on each side of joint with conductor. Fuse holders to be complete with proper fuse to protect luminaire ballast. If required for a festoon circuit the neutral conductor shall be solidly connected and unfused throughout the system.

Ground conductors shall be bonded to standards by a ground lug and to the following by approved grounding methods per national electrical code, ground rod at standard base, feed point enclosure, feed point panels, relay cabinets and ground rods. A continuous #6 solid bare conductor shall be installed from the gel cap splice to the ground rod and then to the ground lug on standard.

3.2.4. ADDITIONAL CONDUCTOR LENGTHS

1. **Splices and conductors in street light standard.** Splices and fuse holders shall have sufficient slack to separately extend 24" outside of the street light standard hand hole, meaning the fuse holder shall be able to extend 24" outside of the standard hand hole while

the gel cap splice is still stored in the shaft of the standard. Splices and fuse holders shall NOT be spooled in bottom of the street light standard, they shall be stored pointing up into the shaft of the standard.

2. **Splices and conductors in pull box.** Splices shall extend a minimum of four feet above finished grade. Splices shall be elevated off the bottom of pull box.
3. **Feed Point.** Spool up an additional three feet for each circuit feeder conductor into bottom of feed point cabinet.

3.2.5. PULL BOX

Install PVC Box. Pull boxes shall be PVC with metal frames and covers, and shall conform to the detail included in the plans. Pull boxes in landscaped areas shall have the top of the box 0" to 1" above final grade and sloped to match the slope of the final grade on all four quadrants. Pull boxes in concrete area shall be set with the top of the box flush with the final grade at all four quadrants.

Install Pull Box. This shall include the cost to supply and install a Polymer Concrete pull box. The minimum size shall be 11" x 18" x 24" deep, with no base. The cover will be 1-3/4" thick, secured with stainless steel bolts, and have a logo of "Street Lights". The base and cover shall be made from a polymer concrete material able to sustain a minimum test load of 12,000#. Color shall be green or gray depending upon location of installation. Carson and Quazite brands are approved for installation. Two feet of crushed rock shall be installed for drainage below the pull box and will extend 6" beyond the outside edge of pull box. The top of box shall be at final grade and sloped to match.

3.2.6. FEED POINT

All street light feed points shall be pad mounted. See plans for details of concrete pad, cabinet size and feed point wiring schematic with number of circuits. Padlock shall be obtained from the City of Fargo Engineering Department.

Pedestal type feed point shall be concrete pad mounted (see plans for details of concrete pad, cabinet size and feed point wiring schematic with number of circuits). The pedestal cabinet shall have a NEMA 3R rating. The cabinet shall be constructed of 16 gauge #304 stainless steel, stainless steel hardware and a padlockable stainless steel handle with 3-point latch operation, continuous hinged deadfront, 2" drip shield, gasketed lexan photocell window on side and back of

pedestal cabinet. All circuit breakers shall be rated 22,000 AIC. The pedestal cabinet shall also include a factory installed, interior mounted meter trim which meets the size requirements of the local utility company and a viewport window with gasketed lexan located on the front door of pedestal cabinet. Meter shall be provided by the local utility company.

Feed points shall require two ground rods that are spaced 6' to 7' apart.

All exposed conduit shall be 2" galvanized steel. Concrete pad, riser (if needed) and other miscellaneous items needed to make feed point operational shall be incidental. Verify connection requirements with the local utility company. The Contractor must contact the project Engineer and local utility company to verify specific location and elevation of feed point and the Contractor shall also communicate with the utility company specific connection requirements. The meter shall be furnished and installed by the utility company.

Prefabricated feed point enclosure to be assembled by States Electric, UL 508 listed, service entrance rated, or approved equal.

3.2.7. STREET LIGHT STANDARDS

Refer to Plans for information on size and type of standards. The Contractor shall take delivery of standards from the manufacturer and shall be responsible for the storage and transportation of standards. The packing material shall be removed from standards when stored outside and as per manufacturer's requirements to prevent damage to standards finish. Packing shall also be removed before any standards are delivered to The City of Fargo. The City of Fargo may purchase additional standards for maintenance stock and the Contractor shall be required to deliver and unload standards as directed to the Street Lighting Department located at 4630 15th Ave. N.

Any damage to the standards will be the Contractor's responsibility to repair or replace as directed by the Engineer.

3.2.8. STREET LIGHT LUMINAIRES

Refer to Plans for information on type of luminaires. The Contractor shall take delivery of luminaires from the manufacturer and shall be responsible for the storage and transportation of luminaires. The City of Fargo may purchase additional luminaires for maintenance stock and the Contractor shall be required to deliver and unload luminaires as directed to the Street Lighting

Department located at 4630 15th Ave. N. All luminaires shall be in their original containers and all luminaires and their containers shall be in new condition.

Any damage to the luminaires will be the Contractor's responsibility to repair or replace as directed by the Engineer.

3.2.9. INSTALL STANDARDS AND LUMINAIRES

Refer to Plans for information on size and type of standards and luminaires. The Contractor shall take delivery of standards and luminaires from the manufacturer or The City of Fargo and shall be responsible for the storage, transportation, installation of standards and luminaires, all wiring within standards and lamps. If the standards and luminaires are supplied by The City of Fargo for installation, the Contractor shall assume the standard one year warranty typically associated with Contractor provided materials.

3.2.10. REMOVE LIGHT STANDARD

The Contractor shall remove standard and luminaire and deliver to the City of Fargo Street Lighting Department located at 4630 15th Avenue North or to an alternate site as directed by the City of Fargo. Any standard/luminaire damaged during the removal, storage or transporting shall be replaced at the Contractors expense.

3.2.11. REMOVE BASE

The Contractor shall remove the concrete base as shown on the plans or as directed by the project Engineer. The Contractor shall backfill and properly compact the disturbed area.

3.2.12. REMOVE FEED POINT

The Contractor shall be responsible for removal of feed point, concrete foundation, conduit, conductor, backfilling and compaction in the disturbed area. The removed feed point shall be delivered to The City of Fargo Street Lighting Department located at 4630 15th Avenue North.

3.2.13. SALVAGE OF MATERIAL

All existing screw-in-bases, standards, luminaires, feed points, conductor and pull boxes designated for removal shall remain the property of The City of Fargo unless otherwise noted on

the plans or directed by the project Engineer. Salvaged screw-in-bases shall have any dirt or other material removed from inside and outside of the bases tube. If material is deemed unsalvageable, it is the Contractors responsibility to dispose of properly. No materials will be allowed to be buried on project site. It shall be the Contractors responsibility to deliver salvaged materials to The City of Fargo Street Lighting Department located at 4630 15th Ave. N., or at an alternate site within the city limits as directed by the project Engineer.

3.2.14. STREET LIGHTING INITIAL AND FINAL INSPECTION AND SUBSTANTIAL COMPLETION

The project will not be classified as substantially complete until the street lighting system is functional, including the completions of all pay items.

After the Contractor has completed the installation of the street lighting system and any clean up items, he shall complete the “Contractor’s Street Lighting Check List”, provided by the City. Each item on the checklist shall be inspected and initialed by the Contractor’s personnel performing this inspection, noting that any deficiencies have been corrected. The Contractor shall forward the completed check list to the project Engineer along with the request for an initial inspection. The Engineer will set a date and time for the inspection. The Contractor shall be present at this inspection and is required to open and close all pull boxes, street light standard hand holes and remove and hold wiring to allow for inspection of splices, fuse holders and anchor bolt nut tightness.

All items requiring additional work after the initial inspection will be noted by the City on the checklist. After the Contractor has completed any deficiencies, the Contractor shall request for final inspection. The project will not be classified as final until the City accepts the project and assigns a final acceptance date. The Contractor is responsible for all maintenance of the street lighting system until the date of final acceptance.

Initial and final inspections will not be performed between November 1st and April 1st. Inspections will not be done if there is rain or snow or wind greater than 15mph or if the temperature is less than 50° F.

The City of Fargo will perform one final inspection at no cost to the Contractor. Additional initial and final inspections shall assess the Contractor a fee of \$500 for each time an additional initial or final inspection is performed.

PART 4
GUARANTEE, MEASUREMENT & Payment

4.1. GUARANTEE

The guarantee shall be per the contract.

4.2. MEASUREMENT AND PAYMENT

Payment for all items shall be full compensation for all labor, material, equipment and miscellaneous items necessary for constructing these items in place.

4.2.1 CONCRETE BASE. The measurement for payment will be for each (EA) size of concrete base installed. Drilling of base hole or hand digging where required, concrete, column forms, anchor bolts, reinforcing rods, conduit, ground rod, and any miscellaneous items necessary for the concrete base will be incidental to the item and will not be measured for payment.

4.2.2. INNERDUCT/CONDUIT. Payment will be made for each size of innerduct/conduit and measured by the linear foot (LF). The measurement for payment will be the length of innerduct/conduit installed from center of concrete base to center of concrete base, pull box or feed point. The method used to install innerduct/conduit (such as boring, jacking or trenching) will not be measured but will be incidental to innerduct/conduit. Cost for street light standard conductor, fuse holders and fuses will not be measured for payment and shall be incidental to the price bid to install standards and luminaires. Couplings/fittings used at concrete bases, and the method of innerduct installation, will not be measured for payment but will be included in the price bid for conduit.

4.2.3. CONDUCTOR. Payment will be made for each size of conductor and measured by the linear foot (LF). The measurement for payment will be the length of conductor installed from center of concrete base to center of concrete base, pull box or feed point. Additional quantities required as shown in the Materials Section will not be measured for payment but shall be incidental.

4.2.4. PULL BOX. The measurement for payment will be for each (EA) type of pull box installed. Pull box, all gel type connectors, backfill and restoration of surrounding area to original conditions will be incidental.

4.2.5. FEED POINT. Measurement and payment will be made for each (EA) feed point installed and operational. Cabinet, concrete foundation and pad, conduit, meter trim, riser with weather head (if

needed), ground rods, conductor and conduit between feed point and transformer (for Xcel Energy areas, sized as per Xcel Energy requirements) and other miscellaneous items needed to have a complete and operational feed point shall be incidental to item. Additional conductor lengths at splices and feed points will not be measured for payment but shall be incidental.

- 4.2.6. STREET LIGHT STANDARD.** The measurement for payment will be for each (EA) type of street light standard supplied for installation, or to be supplied to the City of Fargo for maintenance stock. See plans for type of standard required. The cost bid for this item shall include providing unloading, storage and transportation to project site and to The City of Fargo Street Lighting Department.
- 4.2.7. STREET LIGHT LUMINAIRE.** The measurement for payment will be for each (EA) type of street light luminaire supplied for installation, or to be supplied to the City of Fargo for maintenance stock. See plans for type of luminaire required. Cost of lamp shall be incidental to price bid for luminaire. The cost bid for this item shall include providing unloading, storage and transportation to project site and to The City of Fargo Street Lighting Department.
- 4.2.8. INSTALL STANDARD AND LUMINAIRE.** The measurement for payment will be for each (EA) street light standard and luminaire installed as a complete and operational unit. Incidental to this cost shall be all storage, transportation, all wiring and connections within standards, the standard one year warranty typically associated with Contractor provided materials on City of Fargo supplied standards and luminaires. Cost to install standards with twin mast arms and luminaires shall be incidental to the price bid.
- 4.2.9. REMOVE LIGHT STANDARD.** The measurement for payment will be for each (EA) street light standard removed. The removal and transporting of standards and luminaires shall be incidental to the price bid.
- 4.2.10. REMOVE BASE.** The measurement for payment will be for each (EA) concrete base removed. The removal of foundation/base, back filling and compaction, transporting and disposal of base shall be incidental to the price bid. The removal of foundation/base, back filling and compaction, transporting and disposal of bases shall be incidental to the price bid.
- 4.2.11. REMOVE FEED POINT.** The measurement for payment will be for each (EA) feed point removed. The removal, backfilling and compaction, transportation and disposal of feed point and foundation shall be incidental to the price bid. The removal, backfilling and compaction, transportation and disposal of feed point and foundation shall be incidental to the price bid.

4.2.12. REMOVAL AND/OR SALVAGE OF MATERIALS. Unless specifically called out as a bid item, all costs associated with the removal or salvage of materials, including proper disposal of removed materials and/or delivery of salvaged materials, shall be incidental to the project.

Where a bid item exists for removal and the item is deemed to be salvaged per Section 3 “SALVAGE OF MATERIAL” above, the contract unit price for the removal item shall include all costs to salvage and deliver the material as specified.

4.2.13. BORROWING OF MAINTENANCE STOCK. All costs for the Contractor to borrow City maintenance stock, including all costs for work to load, transport, and unload borrowed and returned materials, shall be considered incidental to the project.

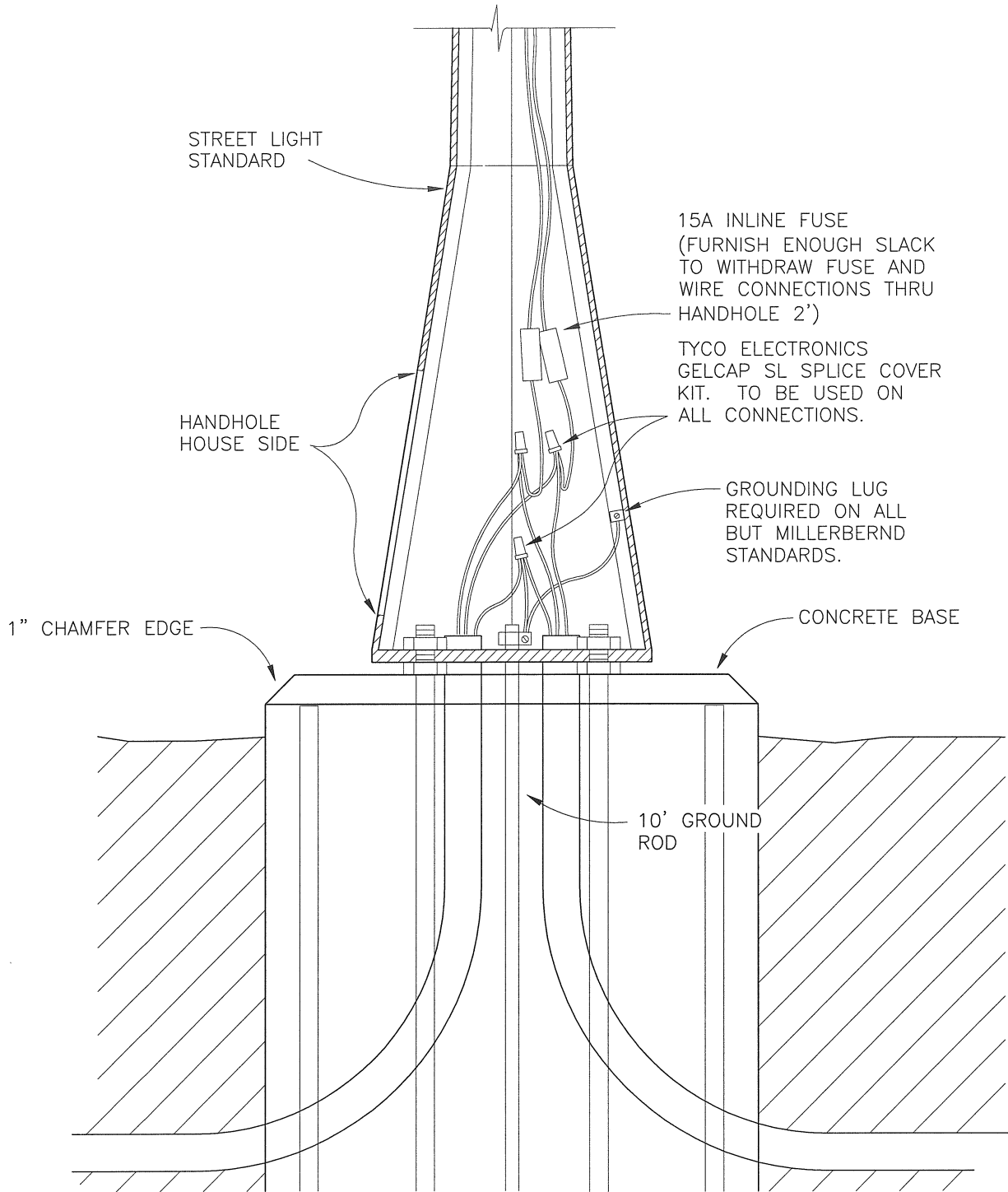

NOTE:
 1. ALL CONDUIT LOCATED IN STREET LIGHT BASES, FEED POINT FOUNDATIONS AND PULL BOXES SHALL HAVE BELL ENDS.

SECTION NO. 4400	DRAWING NO. 5.1
REV.D.	
STANDARD STREET LIGHT FOUNDATION	
CITY OF FARGO ENGINEERING DEPARTMENT	
APPROVED <i>BED</i>	DATE <i>2-21-2012</i>

PEDESTAL TYPE FEED POINT ASSEMBLED BY STATES ELECTRIC: PEDESTAL SHALL BE NEMA 3R RATED ENCLOSURE, CONSTRUCTED OF 16 GAUGE #304 STAINLESS STEEL, CONTINUOUS HINGED DEAD FRONT DOOR, PADLOCKABLE THREE POINT STAINLESS STEEL HANDLE, 2" DRIP SHIELD, GASKETED LEXAN METER SOCKET VIEW PORT WINDOW LOCATED ON FRONT AND PHOTOCELL WINDOW LOCATED ON SIDE AND BACK OF PEDESTAL CABINET.

SINGLE CIRCUIT FEED POINT SHALL BE:
14" WIDE x 48" HIGH x 10" DEEP.

MULTI CIRCUIT FEED POINT SHALL BE:
15" WIDE x 48" HIGH x 12" DEEP.

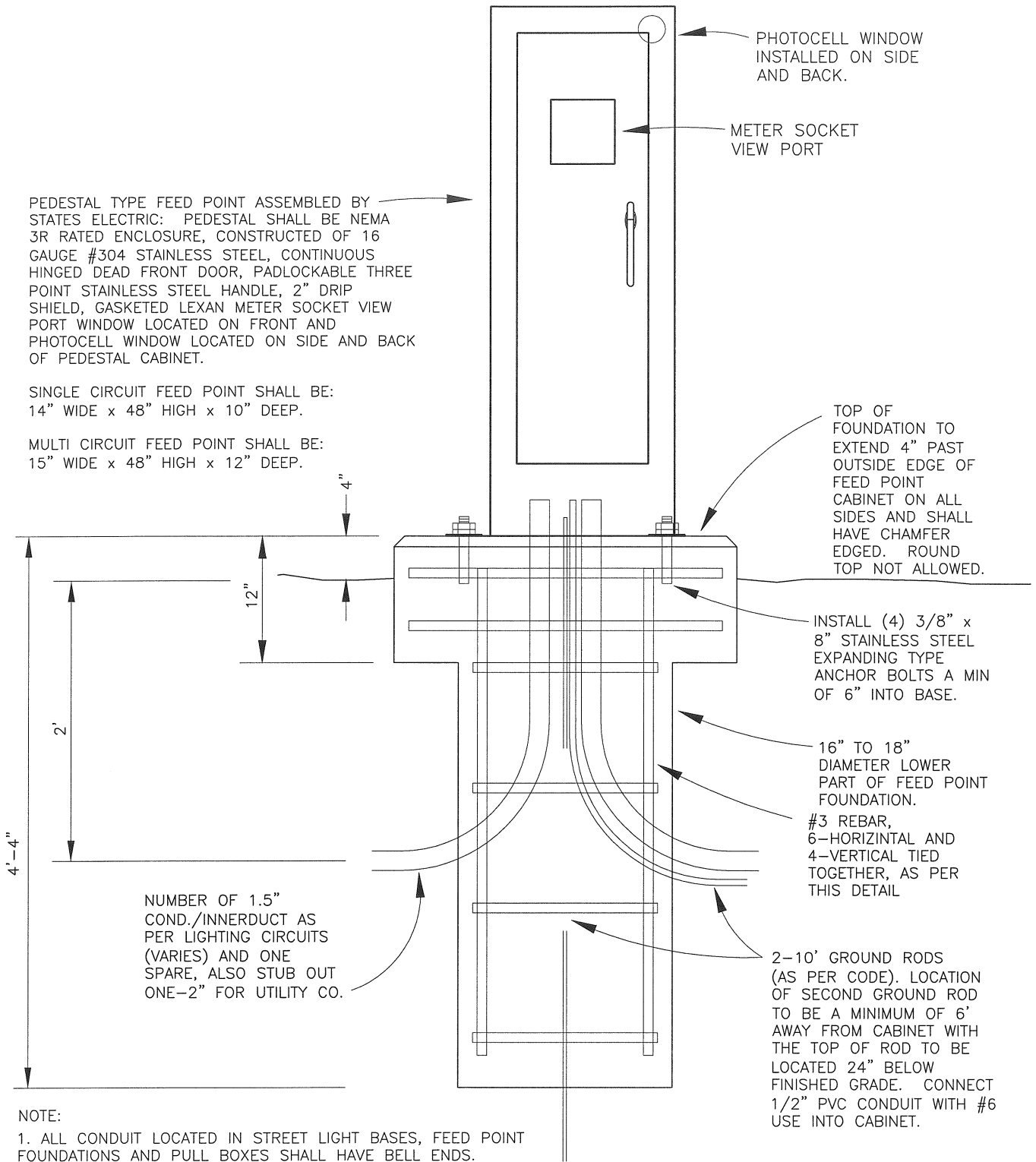

PHOTOCELL WINDOW
INSTALLED ON SIDE
AND BACK.

METER SOCKET
VIEW PORT

TOP OF
FOUNDATION TO
EXTEND 4" PAST
OUTSIDE EDGE OF
FEED POINT
CABINET ON ALL
SIDES AND SHALL
HAVE CHAMFER
EDGED. ROUND
TOP NOT ALLOWED.

INSTALL (4) 3/8" x
8" STAINLESS STEEL
EXPANDING TYPE
ANCHOR BOLTS A MIN
OF 6" INTO BASE.

16" TO 18"
DIAMETER LOWER
PART OF FEED POINT
FOUNDATION.

#3 REBAR,
6-HORIZONTAL AND
4-VERTICAL TIED
TOGETHER, AS PER
THIS DETAIL

2-10' GROUND RODS
(AS PER CODE). LOCATION
OF SECOND GROUND ROD
TO BE A MINIMUM OF 6'
AWAY FROM CABINET WITH
THE TOP OF ROD TO BE
LOCATED 24" BELOW
FINISHED GRADE. CONNECT
1/2" PVC CONDUIT WITH #6
USE INTO CABINET.

NUMBER OF 1.5"
COND./INNERDUCT AS
PER LIGHTING CIRCUITS
(VARIES) AND ONE
SPARE, ALSO STUB OUT
ONE-2" FOR UTILITY CO.

NOTE:

1. ALL CONDUIT LOCATED IN STREET LIGHT BASES, FEED POINT FOUNDATIONS AND PULL BOXES SHALL HAVE BELL ENDS.

SECTION NO. 4400	DRAWING NO. 5.2
------------------	-----------------

REV.D.

*STREET LIGHT FEED
POINT CROSS-SECTION*

CITY OF FARGO
ENGINEERING DEPARTMENT

APPROVED <i>BED</i>	DATE <i>2-21-2012</i>
---------------------	-----------------------

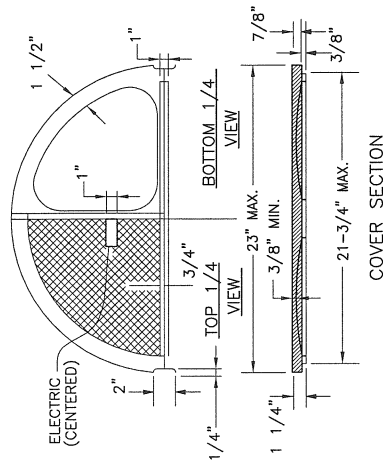
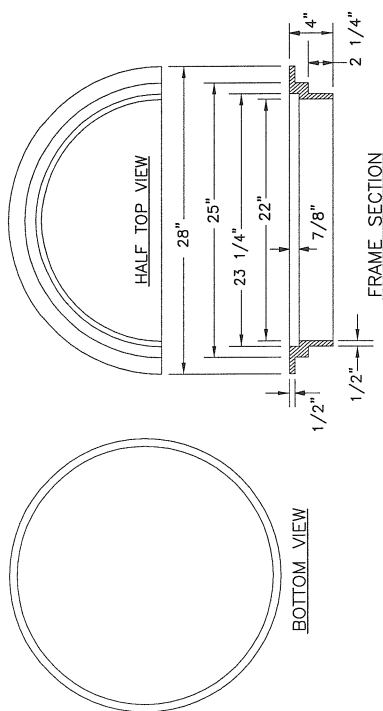

FRAME AND COVER CASTING
 NOTE:
 ALL CASTINGS ARE GRAY IRON AS PER
 SPEC. 3321 CLASS 35B

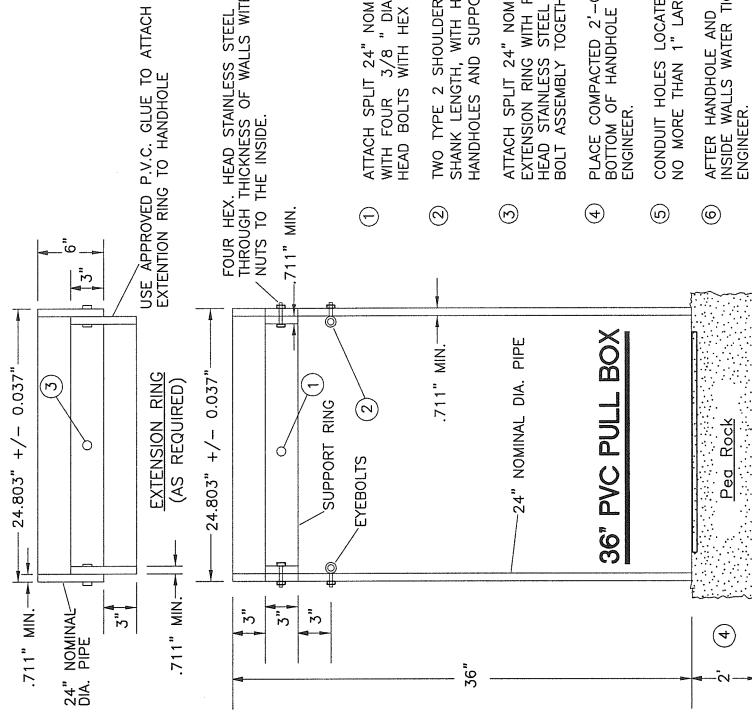

USE APPROVED P.V.C. GLUE TO ATTACH
 EXTENSION RING TO HANDHOLE

FOUR HEX. HEAD STAINLESS STEEL BOLTS
 THROUGH THICKNESS OF WALLS WITH
 NUTS TO THE INSIDE.

- ① ATTACH SPLIT 24" NOM. DIA. P.V.C. COVER SUPPORT RING WITH FOUR 3/8" DIA. X 2" LONG STAINLESS STEEL HEX HEAD BOLTS WITH HEX NUTS AT 90° APART.
- ② TWO TYPE 2 SHOULDER EYEBOLTS, 3/8" DIA. X 1 1/4" SHANK LENGTH, WITH HEX. NUTS AT 180° APART (FOR LIFTING HANDHOLES AND SUPPORTING ELECTRICAL CABLES)
- ③ ATTACH SPLIT 24" NOM. DIA. P.V.C. COVER SUPPORT EXTENSION RING WITH FOUR 3/8" DIA. X 2" LONG HEX. HEAD STAINLESS STEEL BOLTS WITH HEX. NUTS AT 90° APART. BOLT ASSEMBLY TOGETHER.
- ④ PLACE COMPACTED 2'-0" AGGREGATE DRAIN BED BELOW BOTTOM OF HANDHOLE TO THE SATISFACTION OF THE ENGINEER.
- ⑤ CONDUIT HOLES LOCATED IN THE BARREL SECTION ARE SIZED NO MORE THAN 1" LARGER THAN THE CONDUIT USED.
- ⑥ AFTER HANDHOLE AND CONDUIT INSTALLATION, SEAL ALL INSIDE WALLS WATER TIGHT TO THE SATISFACTION OF THE ENGINEER.
- ⑦ THE P.V.C. PIPE COMPLIES WITH ASTM F679T-1.
- ⑧ HEX. HEAD BOLTS AND NUTS ARE TO BE STAINLESS STEEL. OTHER FASTENERS TO BE GALVANIZED AS PER AASHTO M-232
- ⑨ PROVIDE ENOUGH SLACK TO PULL CONDUCTOR AND SPLICES A MINIMUM OF 4' ABOVE FINISHED ELEVATION.

SECTION NO. 4400	DRAWING NO. 5.3
REV.D.	
STREET LIGHT PULL BOX, FRAME, AND COVER	
CITY OF FARGO ENGINEERING DEPARTMENT	
APPROVED <i>BEID</i>	DATE <i>2-21-2012</i>